

Sri – Om

PDF files of VM notes and write ups of Dr. S. K. Kapoor

File 08

<p style="text-align: center;">VEDIC MATHEMATICS FORMAT AND FORMAT OF MODERN MATHEMATICS</p>

CONTENTS

1. Vedic Mathematics format & format of modern mathematics	01-05
2. Bindu Sarovar	06-15
3. Ardh Matra	16-24
4. Tri-Pundarm	25-30
5. Swastik Pada	31-34
6. Word Formulation Pinda	35-43
7. Devnagri Alphabet with TCV value	44-45

VEDIC MATHEMATICS FORMAT AND FORMAT OF MODERN MATHEMATICS

VEDIC MATHEMATICS FORMAT

1. Vedic Mathematics format is of features and values settling the organization format of Vedas.
2. Following 32 scripture will help acquire proper insight and to attain appropriate enlightenment about Vedic Mathematics format.

(i) Rig Ved ऋग्वेद (ii) Yajur Ved यजुर्वेद (iii) Sama Ved समवेद (iv) Atharv Ved अथर्ववेद (v) Ayur upved आयुर्वेद (vi) Dhanur upved धनुर्वेद (vii) Gandharv upved गन्धर्व वेद (viii) Sthapatya upved स्थापत्य वेद (ix) Shiksha शिक्षा (x) Vyakaran व्याकरण (xi) Nirukt निरुक्त (Xii) Chandas छन्दस् (Xiii) Jyotish ज्योतिष् (xiv) Kalpa कल्प (Xv) Sankhya darshan सांख्यदर्शन (xvi) Yoga darshan योगदर्शन (Xvii) Nayaya darshan न्याय दर्शन (xviii) Vaiesheshik darshan वैशेषिकदर्शन (Xix) Purv Mimansa darshan पूर्वमीमांसादर्शन (xx) Brahmsutar / uttar mimansa darshan / vedanta ब्रह्मसूत्र / उत्तरमीमांसादर्शन वेदान्त (XXi) Isha Upnashids ईशः उपनिषदः (XXii) Mandakyo माण्डूक्योपनिषद् (XXiii) Mundakyo मुण्डकोपनिषद् (XXiv) Kena केने उपनिषदः (XXv) Katho कठो उपनिषदः (XXvi) Parshno प्रश्नोपनिषदः (XXvii) Taitettaryo तैत्तरीयोपनिषद् (XXviii) Aeitettariyo ऐतरीयोपनिषद् (XXix)

Swatashwro श्वतेश्वरोपनिषदः (Xxx) Chandagayo
 छन्दोग्योपनिषद् (Xxxi) Brehdaryanka बृहदराण्यका उपनिषदः
 (Xxxii) Sri mad Bhagwad Geeta गीता

3. In addition the Vedic literature (scripture accepting Vedas as source) also will lead to dipper insight about the features and values basis of Vedic Mathematics.
4. One shall sit comfortably and to permit the transcending mind to glimpse and imbibe these values and features and one shall be faced to face with spatial order creator's space with transcendental origin manifesting Vedic Mathematics format.
5. Spatial order itself of zero order and with it Vedic Mathematics format leads to 0-space in the role of dimension of dimension of creator's space (4-space) with transcendental origin (5-space of solid order as origin of creator's space of spatial order).

FORMAT OF MODERN MATHEMATICS

6. Format of modern mathematics is of values and features at the base of the mathematical problems raised and answered during 20th century and continued to be ranged and answered accepting the same values and features.
7. One shall sit comfortably and to permit the transcending mind to glimpse and imbibe these features by being face to face with Hilbert's enlistment of problems in 1900.
8. The problems solved since 1995, the year of proof of Fermat's last theorem, till proof of pentagonal tiling (in 2015),

and till date will help us comprehend as that it is all about taming of surface curve.

9. Modern mind is struggling tame surface curve and is at every step getting blocked with the linearity order and transition there from and transformation in the form of spatial order is eluding comprehensive acceptance on the part of modern mathematical mind is there not only because of the Axioms and postulate but also is because of repulsive response of transcendence at the origin and consciously compatification of whole range of origins of higher dimensional spaces.

0-ORDER OF SPATIAL SPACE

10. Conceptually Vedic systems work with basic constituent of structure being Bindu, a structure point.
11. Word formulation Bindu is of transcendental code value '26'.
12. Value 26 accepts re-organization as $26 = 5+6+7+8$, which is parallel to hyper cube 7, representative regular body of 7-space unity space of transcendental order (5-space in the role of 7-space).
13. One may have a pause here and take note that the operation $[\{(N+(N+2)) + \{N \times (N+2)\} + \{2(N+2)+1\}]$ for odd values of N accept organization as $(M+(M+1)+(M+2)+(M+3))$ parallel to four folds manifestation layers (M, M+1, M+2, M+3) of hyper cube (M+2) with $M = N+4$.
14. One may have a pause here and take note that (N, N+2, N+4) as such is the format of N-space as dimension of (N+2-space and (N+2-space) being dimension of N+4-space.

15. One may further have a pause here and take that this amounts shift from dimension of dimension (N-space) to (N+4) domain.
16. It would be blissful to revisit above for $N = 3$.
17. $(3+5)+(3 \times 5)+(2 \times 5+1) = 34$.
18. Value 34 accepts organization as $34 = 7+8+9+10$, parallel to four folds manifestation layer (7, 8, 9, 10) of hyper cube 9 with 7-space in the role of dimension of 9-space.
19. One shall have a pause here and to permit the transcending mind to glimpse and imbibe the above reach of Vedic mathematics.

-84	-50	-24	-6	4	6	-6	-4	6	24	50	84
-75	-45	-22	-6	3	5	-5	-3	6	22	45	75
-66	-40	-20	-6	2	4	-4	-2	6	20	40	66
-57	-35	-18	-6	1	3	-3	-1	6	18	35	57
-48	-30	-16	-6	0	2	-2	0	6	16	30	48
-39	-25	-14	-6	-1	1	-1	1	6	14	25	39
-30	-20	-12	-6	-2	0	0	2	6	12	20	30
-21	-15	-10	-6	-3	-1	1	3	6	10	15	21
-12	-10	-8	-6	-4	-2	2	4	6	8	10	12
-3	-5	-6	-6	-5	-3	3	5	6	6	5	3
6	0	-4	-6	-6	-4	4	6	6	4	0	-6
15	5	-2	-6	-7	-5	5	7	6	2	-5	-15
24	10	0	-6	-8	-6	6	8	6	0	-10	-24
33	15	2	-6	-9	-7	7	9	6	-2	-15	-33

20. Vedic Mathematics comprehension and imbibing of the features and values of the format of 0-space in the role of

dimension of 2-space has helped to reach at dimensional synthesis values for whole range of dimensional spaces for every number of dimension of same order, being of following tabulation:

MELTING OF MENTAL STATE

21. Modern mathematical mind is of linear order while Vedic mathematical mind is of spatial order mind, as such transition and transformation and for parallel chase format there is a need for melting of mental state of linear order for transition and transformation into as of mental state of spatial order.
22. With this transition and transformation the whole chase would shift from the space within a three dimensional frame of 3 linear dimension into a space within a dimensional frame of quadruple spatial dimension.
23. Sequentially, the transition would proceed ahead, firstly from space within a three dimensional frame of 3 linear dimensions into space within a dimensional frame of quadruple spatial dimensions, and at next step into a space within dimensional frame of Penta solid dimensions.
24. One shall sit comfortably and to permit the transcending mind to glimpse and imbibe these values and features of Vedic Mathematics format vis-à-vis format of modern mathematics.



VEDIC MATHEMATICS FORMAT AND FORMAT OF MODERN MATHEMATICS

(बिन्दु सरोवर) (BINDU SAROVAR)

1. Sadhakas fulfilled with intensity of urge to glimpse and imbibe the values and features of chase format of Vedic Mathematics shall sit comfortably and to permit the transcending mind to glimpse and imbibe word formulation (बिन्दु सरोवर) (BINDU SAROVAR).
2. Formulation (बिन्दु) Bindu is of transcendental code value '26'.
3. Formulation (बिन्दु) Bindu is a composition of pair of syllables (i) (बि) TCV 9), and (ii) (न्दु) TCV 17).
4. One may have a pause here and take note that value 26 with organization $26 = 9+17 = 9+8+9$, with its reversal orientations (-9, -8, -9) brings us face to face with the organization of (-9-space domain) with origin (-8-space) leads to origin transcendence spectrum (-9, -8, -9).
5. One may have a pause here and take note that formulation (बि) is of transcendental code value 9 with organization $9 = 7+2$ and formulation (दु) as well is of transcendental code value 9 but of organization $9 = 6+3$.
6. One may further have a pause here and take note that composition of formulation (बि) = $9 = 7+2$ is parallel to the

format of divya ganga flow from first Component (बिन्दु सरोवर) (BINDU SAROVAR) of sole syllable Om, as seven streams reaching uptill second Component (अर्धमात्रा) Ardh Matra.

7. Further, formulation (दु) of TCV value 9 of organization $9 = 6+3$ is parallel to the format of split of seven streams as a pair of 3 streams towards east and 3 streams towards west and the central streams proceeding ahead for its reach within the pushpika.
8. One may have a pause here and take note that above split is parallel to a split of a three dimensional frames into a pair of three dimensional frames of half dimensions of opposite orientations.
9. One may further have a pause here and take note that devnagri script of values pairs (३, ६) is of opposite orientation.
10. This feature deserves to be comprehended well for its complete comprehension and full appreciation as parallel to it is the composition of organization of formulation (दु) of transcendental code value 9 with organization $9 = 6+3$.
11. One may further have a pause here and take note that the central stream as of its reach with in pushpika, further brings us face to face with word formulation (एक) of transcendental code value (8) parallel to TCV (८) = 8.
12. One may have a pause here and take note that pushpika is of the format of hyper cube 4, the representative regular body of

- 4-space as four space domain enveloped within solid boundary of 8 Components.
13. One may further have a pause here and take note that 4-space is of transcendental origin (5-space as origin) and that 5-space is of a solid order and this as such brings us face to face with the reach of central stream within pushpika making a set up of transcendental domain superimposed with solid order, as a set up and composition $8 = 5+3$.
 14. One shall sit comfortably and to permit the transcending mind to continuously remain in prolonged sitting of trans and to glimpse and imbibe these features and values of composition organization of word formulation (बिन्दु).
 15. Vedic systems approach structure of (बिन्दु) as (सरोवर) / Sarovar / Reservoir.
 16. One may have a pause here and take note that word formulations (बिन्दु) as well as (सरोवर) both accepts transcendental code value 26 each.
 17. Word formulation (सरोवर) is a composition of quadruple syllables (i) (स) of transcendental code value 4, (ii) (रो) of transcendental code value '10', (iii) (व) of transcendental code value '8', (iv) (र) of transcendental code value '4'.
 18. The first syllable (स) of transcendental code value 4 is of organization $4 = 3+1$.
 19. One may have a pause here and take note that values pair (3, 1) is of the format of 3-space domain with 1-space in the role of dimension.

20. Second syllable (रो) is of transcendental code value $10 = 3+7$.
21. One may have a pause here and take note that values pair (3, 7) is parallel to 3-space being of 7 geometries range and parallel to it cube / hyper cube 3 is of 7 versions parallel to representative regular body of 7 geometries of 3-space.
22. Third syllable () is of transcendental code value $8 = 7+1$.
23. One may have a pause here and take note that values pair (7, 1) is parallel to the reach of linear order (1-space in the role of dimension) is uptill 7 progressive steps only.
24. One may have a pause here and take note that hyper circles 1 to 7 increase and from hyper circle 8 onwards there is decrease and this as such makes the reach uptill hyper circle 7 as the upper limit of the linear order reach.
25. Fourth syllable (र) as well is of transcendental code value $4 = 3+1$.
26. One may have a pause here and take note that first and fourth syllables are of transcendental code value four each.
27. The reach from first syllable to the second syllable is reach from value (4 to value 10).
28. One may have a pause here and take note that value pairs (4, 10), is of the format of a reach for 4-space domain uptill creative boundary of ten Components of transcendental domain (4-space as boundary of 10 Component of 5-space domain).
29. Further values pair (4, 10) brings us face to face with $4 = 1+1+1+1$ and $10 = 1+2+3+4$, a pair of affine equal values

- progression (1, 1, 1, 1) and sequential values progression (1, 2, 3, 4).
30. The reach from 4th syllable to 3rd syllable is a reach of values pair (4, 8).
 31. One may have a pause here and take note that values pair (4, 8) is parallel to the format of 4-space domain accepting solid boundary of 8 Components.
 32. Further, 4-space plays the role of origin of 3-space and because of spatial order of 4-space, 3-space splits into eight octants and parallel to it there happens to be a split of cube into sub cubes.
 33. Further, this leads to the internal organization of the volume of cube in-terms of its four internal diagonal coordinating all the eight corner points of the cube.
 34. It further, bring face to face with the set up of 3 dimensional frames of half dimensions imbedded in each of the 8 corner points of the cube.
 35. One shall sit comfortably and to permit the transcending mind to glimpse and imbibe these values and features of composition of formulation (सरोवर) of TCV values range (3, 1, 3, 7, 7, 1, 3, 1).
 36. Inward progression from both ends, as such, here of this range is of opposite orientation as much as that the pair of initial step from one end are of values pair (3, 1) while the same from the other end is of values pair (1, 3).
 37. A step ahead, the progression from the first end is of values triple (3, 1, 7) while from the other end is of values triple (1, 3, 1).

38. One shall sit comfortably and to permit the transcending mind to continuously remain in prolonged sitting of trans and to glimpse and imbibe the values and features of progression format from the first end beginning with value 3 and sequentially reach at values (3, 1), (3, 1, 7), (3, 1, 7, 7).
39. Then, to chase inward progression from the other end as of values steps (1), (1, 3), (1, 3, 3), (1, 3, 1, 7).
40. It would further be a blissful exercise to chase above organization format as of quadruple syllable transcendental code values (4, 10, 8, 4) by plotting them along the circumference for having insight about the internal organization of the syllables themselves:

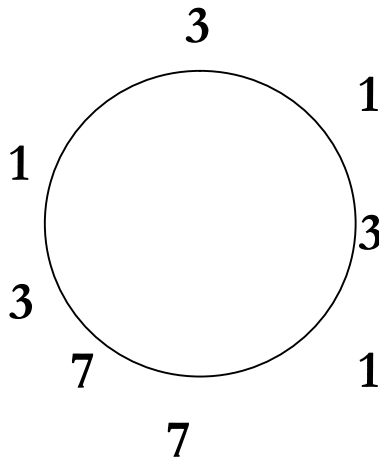

41. One may have a pause here and take note that at fourth step form either ends the reach is at value (7).

42. Pair of values (7, 7) as middle value (14), deserves to be revisited in the light word formulation (Sapt) (सप्त) which is of simple rendering as value (7) while it is of transcendental code value (14).
43. A step ahead, from the middle values pair (7, 7) will sequentially lead us to triple values pairs (3, 1), (1, 3) and (3, 1).
44. One may have a pause here and take note that triple pairs (3, 1), (1, 3), (3, 1) brings us face to face with the double reflection pairing organization, with first phase as of a reach (3, 1) to (1, 3) and at second phase the reach being from (1, 3) to (3, 1), the original position.
45. One shall sit comfortably and to permit the transcending mind to continuously remain in prolonged sitting of trans and fully glimpse above organization feature and values of composition organization format of formulation (सरोवर)..
46. Further one shall revisit quadruple pairs values features:
(i) (7, 7), (ii) 3, 1, (iii) 1, 3, (iv) 3, 1,
47. For their composite value quadruple (14, 4, 4, 4), and also for their first digits (7, 3, 1, 7) and (7, 1, 3, 1).
48. Still further, the chase also shall be for both orientations:
(14, 4, 4, 4) and for (4, 4, 4, 14).
49. Further, as the linear order structure 3-space domain, and a head 4-space domain becomes a domain of spatial order, and as such (4, 4, 4, as first three steps, and (14) being the fourth step, will help us comprehend and to appreciate the re-organization of value $14 = 2+3+4+5$ which is parallel to four

- folds manifestation layer 2, 3, 4, 5 of hyper cube 4, the representative regular body of spatial order 4-space.
50. Further as that $2+2 = 4 = 2 \times 2 = (-2) \times (-2)$ as such not only the addition and multiplication operation get superimposed in distinguishably but also same become the fait of pair of opposite orientation as well..
 51. One may have a pause here and take note that it is because of these features that while linear order mathematics of 3-space permit working in terms of '1' as 1 but the spatial order of 4-space permits working, firstly as '2 as 1 and secondly (1 as 2.
 52. One shall sit comfortably and to permit the transcending mind to continuously remain in prolonged sitting of trans and to glimpse formulation (Sapt), firstly for its simple rending value 7 and then also for its transcendental code value (14).
 53. Sadhakas fulfilled with intensity of urge to fully glimpse and completely imbibe the working steps of Vedic Mathematics of spatial order shall permit the transcending mind to glimpse and imbibe the transcendental origin (5-space as origin) of solid order of spatial order creative space (4-space) with 2-space as dimension.
 54. Creator's space (4-space) being of spatial order, same permits progression along a pair of streams, and likewise the transcendental space (5-space) because of its solid order permit progression as triple streams.
 55. One shall permit the transcending mind to glimpse and imbibe the following progression, at the fifth step for four folds manifestation layers (2, 3, 4, 5) of summation value 14.

- (i) (2, 3, 4, 5) of reach (2, 3, 4, 5, 6) as a linear progression.
- (ii) (2, 3, 4, 5) as (2, 3, 4, 5, 5) as spatial progression.
- (iii) (2, 3, 4, 5) as [$\{2, 3, 4, 5\}$, (2, 3, 4, 5), (2, 3, 4, 5)]
56. One may have a pause here and take note that (2, 3, 4, 5, 6) is of summation value $20 = 14+6$.
57. Further 2, 3, 4, 5, 5 is of summation value $19 = 14+5$.
58. Still further, [$\{2, 3, 4, 5\}$, (2, 3, 4, 5), (2, 3, 4, 5)] is of summation value $42 = 14+28$.
59. One may have a pause here and take note that value (6) is the first perfect number value.
60. Further value 28 is the second perfect number value.
61. Value 6 is of 3 proper divisors, while value 28 is of 5 proper divisors and values pair (3, 5) is of format of 3-space as dimension and 5-space as domain.
62. It will be blissful to take note that value 20 is parallel to transcendental code value of formulation (वेद), as well of (देव).
63. And, value 19 is parallel to transcendental code value 19 of formulation (सविता) as well as of (कृष्ण)
64. And, value 42 is parallel to transcendental code value 42 of formulation (तत्त्वज्ञान).
65. Vedic systems reach is the reach of (क्षेत्रं क्षेत्रज्ञ तत्त्वज्ञान), the essence of values and virtues of existence phenomenon.
66. It would be blissful exercise to fully glimpse and imbibe the values and features of formulations (क्षेत्रं क्षेत्रज्ञ तत्त्वज्ञान).

67. Formulation (क्षेत्रं) is of transcendental code value 20 which is parallel to synthesis value of a pair of transcendence range of zero order: $(0+1+2+3+4)+(0)+(0+1+2+3+4) = 20$.
68. Formulation (क्षेत्रज्ञ) is of transcendental code value 31, which is parallel to synthesis value of a pair of transcendence range of linear order $(1+2+3+4+5)+(1)+(1+2+3+4+5) = 31$.
69. Formulation (तत्त्वज्ञान) is of transcendental code value 42 which is parallel to synthesis value of a pair of transcendence ranges of spatial order: $(2+3+4+5+6)+(2)+(2+3+4+5+6) = 42$.
70. One may have a pause here and take note that value 42 accepts organization as $42 = 21+21$ and value 21 accepts organization as $21 = 1+2+3+4+5+6$ which is parallel to self referral (1, 2, 3, 4, 5, 6) of the format and features of Sathapatya measuring rod synthesized by hyper cubes 1 to 6 of values and virtues of format of swapping of self referral domain of Surya (Sun), a real 6-space body.
71. One shall sit comfortably and to permit the transcending mind to continuously remain in prolonged sitting trans and to glimpse and imbibe the above values and features of Vedic systems attainment of the order of (क्षेत्रं क्षेत्रज्ञ तत्त्वज्ञान).



VEDIC MATHEMATICS FORMAT AND FORMAT OF MODERN MATHEMATICS

(अर्धमात्रा) (ARDH MATRA)

(ॐ इत्येकाक्षरं ब्रह्म)

SOLE SYLLABLE OM

(बिन्दु सरोवर)		Bindu-Sarovar
(अर्धमात्रा)		Ardh Matra
(त्रिपुण्ड्र)		Tri-Pundram
(स्वास्तिक पाद)		Swastik Pada
(सनातन)		Sanatana

1. Sadhakas fulfilled with intensity of urge to acquire proper insight and to attain appropriate enlightenment of vedic systems shall permit the transcending mind to continuously remain in prolonged sitting of trans and to glimpse and imbibe the values and features, as well as the organization

format of Enlightenment: (ॐ इत्येकाक्षरं ब्रह्म) (Om Iti Ek Akshar Braham) / Sole Brahman Syllable Om.

2. Along artifices of quadruple Components [बिन्दु सरोवर (Bindu Sarovar), अर्धमात्रा (Ardh Matra), त्रिपुण्ड्र (Tri-Pundram) and स्वास्तिक पाद (Swastik Pada)] of sole syllable Om flow Divya-Ganga flow and attains its reach in Brahman domain.
3. Sadhakas fulfilled with intensity of urge to glimpse and imbibe the sequential flow steps of Divya-ganga along sole syllable Om shall be face to face with the transcendental code values of formulation [बिन्दु सरोवर (Bindu Sarovar), अर्धमात्रा (Ardh Matra), त्रिपुण्ड्र (Tri-Pundram) and स्वास्तिक पाद (Swastik Pada)]:
 - (i) TCV (बिन्दु सरोवर) = 52
 - (ii) TCV (अर्धमात्रा) = 29
 - (iii) TCV (त्रिपुण्ड्र) = 51
 - (iv) TCV (स्वास्तिक पाद) = 37
4. It would further be blissful to take note that TCV (सनातन) = 28 is parallel to TCV (ब्रह्म) = 28.
5. One may have a pause here and take note that value 52 with its organization $52 = 13 \times 4$, is parallel to 13 creative dimensions (4-space as dimension of 6-space with 13 geometries range) and with it one come face to face with Bindu Sarovar (बिन्दु सरोवर), a point reservoir being fulfilled with parallel structure of 6-space domain.

6. One may further have a pause here and take note that value 6 is the value of first perfect number (6) while value 28 is the value of second perfect number (28).
7. One shall sit comfortably and to permit the transcending mind to glimpse and imbibe to flow format of Divya-ganga flow as of reach from first perfect number (6) to second perfect number (28).

ARDH MATRA (अर्धमात्रा)

8. Formulation (अर्धमात्रा) is of transcendental code value 29.

(अर्धमात्रा)

$$(1+2+7+1+9+2+4+1+2 = 29)$$

अ	८	ध्	अ	म्	आ	त्	८	आ
1	2	7	1	9	2	4	1	2

9. Value 29 is parallel to domain split spectrum at its fourth phase split:

$$(1, 2, 5, 12, \mathbf{29}, 70, 169, 408, 985, \dots)$$

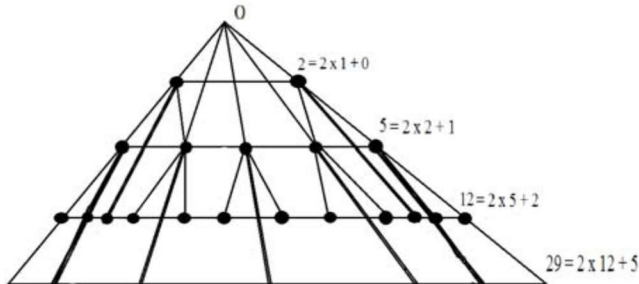

10. Further, value 29 accepts organization as $29 = 15+14$, parallel to the set up of 15 points along with their 14 gaps.
11. One may have a pause here and take note that formulation (स्वर) (vowel) is of transcendental code value 15 while the formulation (व्यञ्जन) (Consonant) is of transcendental code value (29).
12. One shall sit comfortably and to permit the transcending mind to continuously remain in prolonged sitting of trans and to glimpse and imbibe value 29 as transcendental code value of Ardh Matra, as well as of Vyanjan.
13. Further as that, value 29 is the value of domain split at 4th phase.
14. Still further, as that, Sama Ved samhita is a scripture of 29 Archiks.
15. Fifth chapter of Srimad Bhagwad Geeta is of 29 Shalokas range.
16. Srimad Durga Sapt Sati is a scripture with its last (13th) chapter being of the range of 29 Shalokas / Ardh Shalokas / Uvachas, all together.
17. One shall sit comfortably and to continuously remain in prolonged sitting of trans to glimpse and imbibe these values and features.
18. One may further have a pause here and take note that value 29 accepts organization: $29 = 2 \times 14 + 1$, which is parallel to 29 versions of hyper cube 14 as a four folds manifestation layers (12, 13, 14, 15) of summation value $12+13+14+15 = 54$

which accepts (domain, dimension format with value (52) as TCV of formulation Bindu Sarovar (बिन्दु सरोवर).

19. One may have a pause here and take note that value 14 accepts organization as $14 = 2+3+4+5$, which is parallel to four folds manifestation layers 2, 3, 4, 5 of hyper cube 4, the representative regular body of creator's space (4-space).

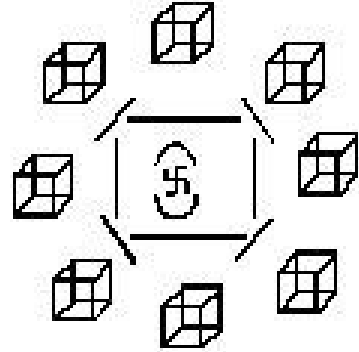

20. It would be blissful to take note that lord Brahma, four head lord, with a pair of eyes in each head, and of lotus seat of eight petals, with seat of transcendental lord in the cavity of his heart and formulation Brahma (ब्रह्मा) is of transcendental code value (29).

(ब्रह्मा)

$$(7+1+1+9+9+2 = 29)$$

ब्	-	अ	ह्	म्	आ
7	1	1	9	9	2

21. One shall sit comfortably and to permit the transcending mind to fully glimpse the phenomenon of re-manifestation of manifested format of hyper cube 4.
22. Hyper cube 4 as four folds manifestation layers (2, 3, 4, 5) of summation value 14 and hyper cube 14 as four folds manifestation layers 12, 13, 14, 15 of summation value 54 is of 29 versions.
23. One may have a pause here and take note that value 54 accepts organization as $54 = 27+27 = 3^3 + 3^3$.
24. Further as that, $29 = 16+13$.
25. One may have a pause here and take note that numbers range 1 to 16 leads to $16+13 = 29$ factors in all:

Number	Factors	Number of factors	Total factors
1	1	1	1
2	2	1	2
3	3	1	3
4	2x2	2	5
5	5	1	6
6	2x3	2	8
7	7	1	9
8	2x2x2	3	12
9	3x3	2	14
10	2x5	2	16
11	11	1	17
12	2x2x3	3	20
13	13	1	21
14	2x7	2	23

15	3×5	2	25
16	$2 \times 2 \times 2 \times 2$	4	29

26. It would be blissful to take note that there are 16 Ganita Sutras and 13 Ganita Upsutras.

27. One may further have a pause here and take note that dimensional frame of creator's space (4-space) is a set up of quadruple spatial dimension which lead to pair of organizations:

$$(i) \quad 2+2+2+2 = 8,$$

$$(ii) \quad 2 \times 2 \times 2 \times 2 = 16$$

28. One may further have a pause here and take note that:

$$(i) \quad \text{TCV (एक)} = 8$$

$$(ii) \quad \text{TCV (द्वय)} = 16$$

29. It would be blissful to comprehend and imbibe as that, manifestation of square with a feature of re-manifestation as interval and square within square, is the attainment which is the attainment of Vedic systems, for which the modern mathematical systems have to transit and transform to be in unison with the chase steps of Vedic Mathematics along the format of creator's space (4-space) of a spatial order.

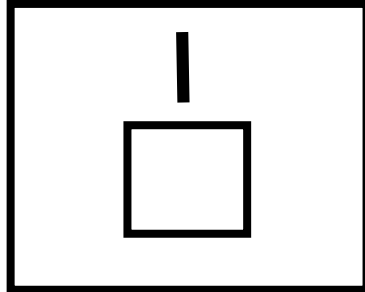

30. One shall further have a pause here and to take note that spatial order of creator's space accepts a two folds approach, firstly as '2 as 1' and second as '1 as 2'.
31. One shall sit comfortably and to permit the transcending mind to continuously remain in prolonged sitting of trans to glimpse and imbibe above values and features of Vedic Mathematics of creator's space.
32. It would be blissful to revisit two phased manifestation, firstly as hyper cube 4 and secondly as hyper cube 14.
33. One may have a pause here and take note that hyper cube 14 has 12-space in the role of dimension.
34. It would be very blissful to take note that:
- (i) TCV (एक) = TCV (त्रय) = TCV (चार) = 8
 - (ii) TCV (चतुर) = 12
 - (iii) TCV (चत्वार) = 20 = 8+12
35. One shall sit comfortably and to permit the mind to glimpse and imbibe above values and features of mathematics of format of creator's space (4-space) of spatial order.
36. It would further be blissful to take note that value 16 is parallel to the transcendental code values range 1 to 16 of the alphabet letters of devnagri alphabet.
37. It would further be blissful to take note that Creator's space has transcendental origin while transcendental domain itself is of self referral origin and transcendence of self referral origin of transcendental domain leads to split spectrum of values range (5, 6, 5) of summation value $5+6+5 = 16$.
38. Further as that, the re-manifestation phenomenon as of first phase of 1-space as dimension manifesting 3-space domain,

and at second stage of manifestation, 3-space as dimension manifests 5-space as domain.

39. One shall sit comfortably and to permit the transcending mind to glimpse and imbibe the organization of summation value (54 of four folds layer of hyper cube 14 (12, 13, 14, 15) as $12+15 = 13+14$, as the outer fold and inner fold of value 3^3 each will brings us face to face with the phenomenon of 27 Surya Nakshatras and 27 Chandar Nakshatras, a simultaneously parallel phenomenon of northern hemisphere and southern hemisphere of our solar universe.

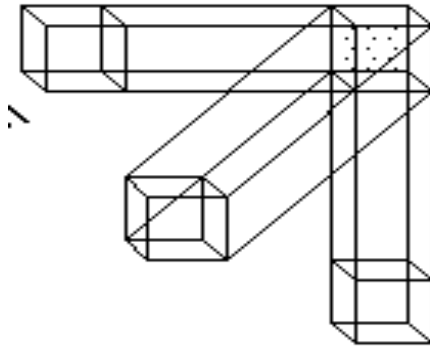

40. Sadhkas fulfilled with intensity of urge to glimpse and imbibe the way one may reach at the optimum reach of Vedic systems, one is to sequentially be through shad Vedangas and thereafter to be within the Vedic Samhita domain.



VEDIC MATHEMATICS FORMAT AND FORMAT OF MODERN MATHEMATICS

(त्रिपुण्ड्र) TRI-PUNDRAM

1. Tri-Pundram is the third Components of Om formulation.
2. Formulation (त्रिपुण्ड्र) Tri-Pundram accepts (41) as transcendental code value:

(त्रिपुण्ड्र) Tri-Pundram

$$(4+1+2+5+3+7+5+4+1+9 = 41)$$

त्	-	इ	प्	उ	ण्	ङ्	^	अ	.
4	1	2	5	3	7	5	4	1	9

3. One may have a pause here and take note that value (41) avails a pair of digits (4), (1) for their placement along the ten place value format.
4. Quadruple Components in there sequence as Bindu Sarovar, Ardh Matra, Tri-Pundram, Swastik Pada accepts sequential placement value as (1, 2, 3, 4):

(बिन्दु सरोवर)		Bindu-Sarovar
(अर्धमात्रा)		Ardh Matra
(त्रिपुण्ड्र)		Tri-Pundram
(स्वास्तिक पाद)		Swastik Pada
(सनातन)		Sanatana

5. Sadhakas fulfilled with intensity of urge to glimpse and imbibe the distinctive feature of letter Raif (रेफ) (र), shall glimpse and imbibe following features and particulars:

- (i) Formulation Raif is of transcendental code value $16 = 3+6+6+1$.
- (ii) All other letter are (कार) of transcendental code value 7.
- (iii) Letter Raif (र) is of four folds:

रेफ (9+6)

1	2	3	4
---	---	---	---

- (iv) TCV (षोडश) = 26, while simple value rendering of this formulation is (16).

- (v) Quadruple values (1, 2, 3, 4) is of summation value $(1+2+3+4) = 10$.
 - (vi) Quadruple values as quadruple spaces 1-space, 2-space, 3-space, 4-space lead to dimensional frames of single, double, triple, quadruple dimensions making a set of 10 dimensions of (-1, 0, 1, 2) order, of summation value '2'.
 - (vii) The quadruple values (1, 2, 3, 4) as first manifestation (hyper cube1, hyper cube 2, hyper cube 3, hyper cube 4) of four folds each, at the second manifestation make a set of $4 \times 4 = 16$ dimensions set.
 - (viii) The domain split spectrum, uptill first phase is of 4 stream, while the same uptill second split is of ten streams.
 - (ix)
6. One shall sit comfortably and to permit the transcending mind to glimpse and imbibe these values and features to acquire proper insight and to attain appropriate enlightenment about the distinctiveness of letter Raif.
 7. The quadruple value, 1, 2, 3, 4, is parallel to four folds manifestation layers (1, 2, 3, 4) of hyper cube 3.
 8. One shall sit comfortably and to permit the transcending mind to glimpse and imbibe the feature and value as that letter (ॠ) accepts association of value (3).
 9. The formulation Tri-Pundram is the third Components and is of TCV value 41, and the same as such, deserves to be comprehended fully in the set up of quadruple values (52, 54,

- 41, 36) of quadruple formulation of quadruple Components of Om formulation.
10. The pair of values (52, 41) leads to $52+41 = 93$ and $52-41 = 11$ value.
 11. Values pair (54, 41) leads to $54+41 = 95$ and $54-41 = 13$ value.
 12. The organization $54 = 27+27$, as such, brings to focus:
 - (a) $41 = 27+14$
 - (b) Hyper cube 4 as of spatial order with transcendental origin of solid order and there being split for the solid dimensional frame as a pair of solid dimensional frames of half dimensions of values pair $(3^3, 3^3)$
 13. One may have a pause here and take note that the hyper cube 4 as first manifestation (2, 3, 4, 5) is of summation value 14 and at second manifestation as hyper cube 14 (12, 13, 14, 15) is of value 54, the same at next manifestation as hyper cube 54 (52, 53, 54, 55) is of summation value 107.
 14. One may have a pause here and take note that $107 = 80+27$ and value 80 accepts organization as $80 = 8 \times 10$ which is parallel to 80 cubes envelop of entire creative boundary (4-space as boundary) of 10 Components of transcendental domain (5-space domain) of solid order.
 15. One may have a pause here and take note that the manifestation layers 52, 53, 54, 55 is of value 55 for its origin fold.
 16. Value $55 = 5 \times 11$ as such is the value of dimensional frames of 5 dimensions for each of 11 geometries of 5-space.

17. One may have a pause here and take note that $55 = 14+41$ and $14 = 2+3+4+5$, as such brings us face to face with the transcendental phenomenon of third phase of manifestation with in creator's space (4-space) of transcendental origin.
18. One may have a pause here and take note that double digit number of ten place values systems are accommodated by 9×11 grid, which splits as upper part and lower part and the upper part is having a mirror line (11, 22, 33, 44) while the lower part is having a mirror line (55, 66, 77, 88, 99).
19. It will be a blissful exercise to visit the organization format of upper part and to tabulate its reflection pair including self reflection artifices along the mirror line as a set up of 29 such pairs which accepts classification as 16 pairs and 13 pairs respectively parallel to the organization of 16 Ganita Sutras and 13 Ganita Upsutras.
20. It would further be blissful exercise to tabulate reflection pair set up of the lower part with its mirror line (55, 66, 77, 88, 99) sublime penta self reflecting pairs of values (55, 66 77, 88, 99).
21. For convenient reference the tabulation of double digit number as 9×11 grid is being reproduced as under:

01	02	03	04	05	06	07	08	09
10	(11)	12	13	14	15	16	17	18
19	20	21	(22)	23	24	25	26	27
28	29	30	31	32	(33)	34	35	36
37	38	39	40	41	42	43	(44)	45
46	47	48	49	50	51	52	53	54
(55)	56	57	58	59	60	61	62	63
64	65	(66)	67	68	69	70	71	72
73	74	75	76	(77)	78	79	80	81
82	83	84	85	86	87	(88)	89	90
91	92	93	94	95	96	97	98	(99)

VEDIC MATHEMATICS FORMAT AND FORMAT OF MODERN MATHEMATICS

(स्वास्तिक पाद) SWASTIK PADA

1. Formulation (स्वास्तिक पाद) Swastika pada is of transcendental code value $23+14 = 37$.

(स्वास्तिक पाद)

$$(3+7+2+3+4+2+1+1+5+2+6+1 = 23+14)$$

स्	व्	आ	स्	त्	इ	क्	अ	प्	आ	द्	अ
3	7	2	3	4	2	1	1	5	2	6	1

2. One may have a pause here and take note that the formulation (श्रीभगवान) Sri Bhagwan = 37.
3. One may have a pause here and take note that value 37 accepts organization as $37 = 2 \times 18 + 1$, which is parallel to 37 versions of hyper cube 18 as representative regular body of 37 geometry of 18-space.
4. Value 23 is of organization $23 = (3+5) + (3 \times 5)$, which is parallel to summation value of addition and product of pair of values (3, 5) parallel to 3-space as dimension of 5-space.
5. Value 14 is of organization $14 = 2+3+4+5$, which is parallel to four folds manifestation layers (2, 3, 4, 5) of hyper cube 4, the representative regular body of 4-space with 5-space in the role of origin.

- One may have a pause here and to permit the transcending mind to continuously remain in prolonged sitting of trans and to glimpse and imbibe above values and features of the set up of hyper cube 4 with transcendental origin.

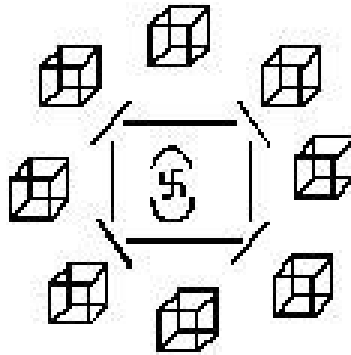

- One may further have a pause here and take note that Swastik (23) as Pada (quarter) will bring us face to face with the set up of value $23 \times 4 = 92$.
- One may further have a pause here and take note that value $23 \times 4 = 92$ is parallel to splits spectrum of domain (25).

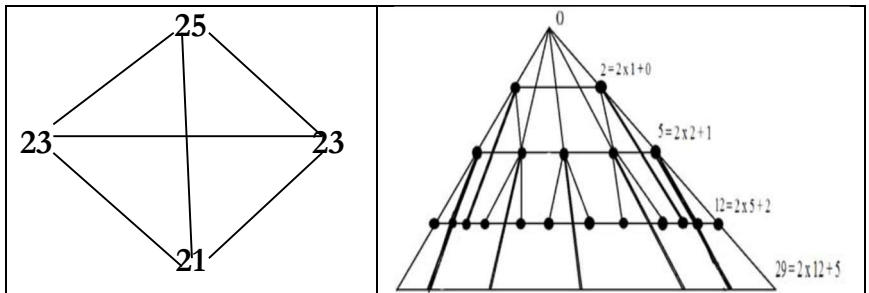

9. Sadhakas fulfilled with intensity of urge to acquire proper insight and to attain appropriate enlightenment about these organization format features and values shall be face to face with the following word formulations as well:
- (i) **25** = TCV (विष्णु) (बुद्धि) (पृथ्वी) (दुःख) (भूमि)
- (ii) **23** = TCV (जन्म) (अन्नत) (सहस्र)
- (iii) **21** = TCV (मृत्यु) (ज्ञान) (तत्त्व) (आरम्भ) (पुराण)
10. One may have a pause here and to permit the transcending mind to glimpse fully the phenomenon of split of domain-28 as a pair of stream of value (26) each.
11. It would be blissful to take note that value 28 is parallel to transcendental code value of formulation Brahm (ब्रह्म) = 28, while values pair (26, 26) is parallel to TCV value (बिन्दु सरोवर).
12. It would further be blissful to glimpse and imbibe four folds manifestation layers (23, 24, 25, 26) of hyper cube 25.
13. Here, space 23 plays the role of dimension while space 26 plays the role of origin of hyper cube 25.
14. One shall sit comfortably and to chase Divya Ganga parvaha from Bindu Sarovar (बिन्दु सरोवर) and its reach within Pushpika (hyper cube 4) uptill its transcendental origin, and transcendence back from transcendental origin of pushpika and its reach back uptill orb of the Sun, the seat of Bindu Sarovar of Sole Syllable Om.
15. Sadhakas fulfilled with intensity of urge to glimpse and imbibe this phenomenon shall glimpse and imbibe the

organization format of Srimad Bhagwad Geeta being of the format and features of Divya Ganga Parvaha along the artifices of the Component sole Syllable Om.

16. And, the organization format of Sama Ved Samhita being of the format and feature of transcendence upward from the transcendental origin and its reach uptill orb of the Sun as a seat of (बिन्दु सरोवर).



VEDIC MATHEMATICS

(MATHEMATICS OF (पिण्ड) PINDA)

Word formulation (पिण्ड) (*Pinda*) /Body / Human body)

1. Word formulation (पिण्ड) is a composition availing 5 letters of transcendental code values (5, 2, 7, 5, 1) of summation value (20).

(पिण्ड)

$$(5+2+7+5+1 = 20)$$

प्	इ	ण्	ङ्	अ
5	2	7	5	1

2. First letter (प्) is of transcendental code value (5) and parallel to it is 5-space, and the same as per the placement of letter (प्) as first letter of the fifth row of varga consonant is of format of 5-space in the role of dimension making it a transcendental dimensional order of unity state (7-space domain).
3. Second letter (इ) is of transcendental code value (2), the same is of format of dimensional frame of 2-space, which as such is a set up of a pair of dimensions of zero order.
4. Third letter (ण्) is of transcendental code value (7), parallel to which is 7-space, which as per the placement of letter (ण्) is of the format of 7-space as base fold of hyper cube 5.

5. 4th letter (इ) is of transcendental code value (5), parallel to which is 5-space, which as per the placement of letter (इ) is in the role of 5-space as domain fold of hyper cube 5.
6. 5th letter (अ) is of transcendental code value (1), parallel to which is 1-space, and same as per placement of letter (अ) is of the format of a dimensional frame of 1-space, which is of format and features of single dimension of negative linear order (-1-space in the role of dimension of 1-space).

NUMBER VALUE 20

7. Number value 20 is parallel to transcendental code value 20 of formulation Ved (वेद), as well as of formulation (देव) Dev.
8. One may have a pause here and take note that value 20 is parallel to synthesis value 20 of a pair of transcendence range of zero order: $[(0+1+2+3+4)+(0)+(0+1+2+3+4)]$.
9. One may further have a pause here and take note that the summation of values of single, double, triple and quadruple dimension synthetic set up of for every order, comes to be '20':

$$[\{N\} + \{N+2\} + \{6\} + \{-2N-12\}] = 20, \text{ for all value of } N.$$
10. Still further, as $0+0 = 0 = 0 \times 0 = (-0) \times (-0) = (-0)$, as such the orientation gets dissolved in zero order set ups.
11. Still further, $2+2 = 4 = 2 \times 2 = (-2) \times (-2)$, as well dissolves orientations in a spatial order 4-space.
12. One shall sit comfortably and to permit the transcending mind to continuously remain in prolonged sitting of trans and

to glimpse and imbibe the above values and features of creator's space (4-space) which is of spatial dimensional order (2-space in the role of dimension of 4-space) and these also of zero dimension of dimension, 0-space plays the role of dimension of 2-space and dimension of dimension of 4-space.

13. It would be blissful to glimpse value 20 in reference to value (-20).
14. It would be blissful to visit organization of value (-20) as [-7, -7, -6].
15. One may have a pause here and take note that this set up and organization (-7, -7, -6) in its reverse orientation as (7, 7, 6) is parallel to the set up of word formulation (पिण्ड) Pind being of transcendental code values [(5+2 = 7), (7), (5+1 = 6)].
16. One shall sit comfortably and to permit the transcending mind to continuously remain in prolonged sitting of trans and to glimpse and imbibe the above format and feature to imbibe them completely for fully appreciation to acquire proper insight and to attain appropriate enlightenment about the organization format of word formulation (पिण्ड).

CIRCUMFERENCE FORMAT FOR VALUES RANGE

(2, 5, 7, 5, 1)

17. Sadhakas fulfilled with intensity of urge to fully glimpse and to completely imbibe the organization format of composition

of word formulation (पिण्ड) shall visit it in the sequence and placement of letters as:

(पिण्ड)

$$(2+5+7+5+1 = 20)$$

इ	प्	प्	ड्	अ
2	5	7	5	1

18. Let us have a transition and transformation from that of a line to that a circumference:

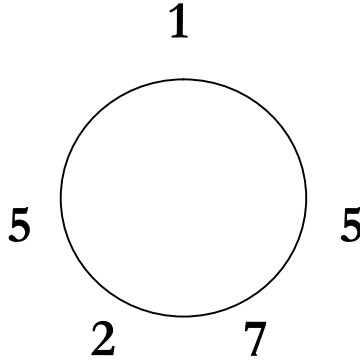

19. One may have a pause here and take note that from value '1' we shall be having twin progression flow, firstly as of reach (1, 5, 2) and second as of (1, 5, 7).

20. One may have a pause here and to have a visit to the set up of Divya Ganga Prahvaha along the artifices of Component of sole syllable Om (Y) (Bindu Sarovar, Ardh Matra, Tri-Pundram and Swastik Pada).

From the bindu Sarovar flow 7 streams and with the reach uptill second Component.

21. One may have a pause here and take note that Bindu Sarovar as first Component accepts association of value (1), and in a sequence, second Component (Ardh Matra accepts association of number value (2).
22. One may have a pause here and take note that from first Component there is going to be a reach second Component.
23. And, simultaneously from first Components there is going to be a reach as of seven stream flow emanating from the Bindu Sarovar (first Component).
24. This as such, makes first path as of values pair (1, 2).

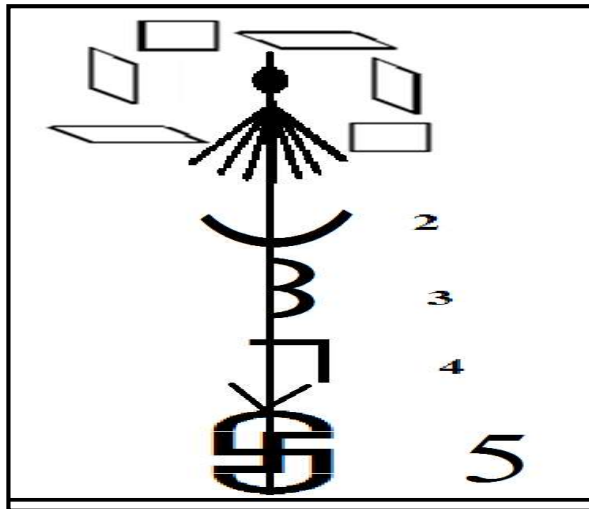

25. Simultaneously, it also leads to second progression path of values pair (1, 7).
26. One may further have a pause here and to glimpse and imbibe the format and features of the above organization of 7

- streams fulfilling the space between first Component (Bindu Sarovar) uptill the second Components (Ardh Matra).
27. As such, with first Components, as the first end point of the covered domain, and the second Components as the second end point of covered domain, a reach from both end, will help us comprehend and imbibe the format and feature of the composition of formulation (पिण्ड) availing pair of vowels (अ, इ), as a pair of end letters of the composition (पिण्ड) as of five letters in all.
 28. One may have a pause here and take note that from both end, the inward progression, in both cases, is at value '5' as the letters (ऋ) and (ॠ), both of them accept value (5) each.
 29. One may have a pause here and take note that dimensional synthesis equation $(5, 5) = (7)$ will help us appreciate as to the reach at the inner most letter (ऋ) is going to be value (7).
 30. One may further have a pause here and take note that values pair (2, 5) are also interconnected and interrelated as that 2-space as 5 geometries range and parallel to it hyper cube 2 / square is of 5 versions making a set of 5 representative regular body of 2-space.
 31. Further, values pair (5, 7) is interconnect and interrelated as of format of 5-space in the role of dimension of 7-space domain.
 32. Still further, it also would be relevant to take note that 3-space plays the role of origin of 2-space and 3 dimensional frames accepts split as a pair of 3 dimensional frames of half dimensions.

33. Further as that, pair of solid dimensions (3, 3) lead to synthesis value (5) as synthesized domain $(3, 3) = (5)$.

REACH FROM PIND (पिण्ड) TO BRAMAND (ब्रह्माण्ड)

34. Sadhakas fulfilled with intensity of urge to completely comprehend and fully appreciate the organization of word formulation () Pind shall sit comfortably and to permit the transcending mind to glimpse and imbibe the format features of five steps long composition of formulation Pind as format of word formulation Brahmand (ब्रह्माण्ड) of transcendental code value '42'.
35. One may have a pause here and take note that value (20) accepts organization as $20 = 6+14$.
36. Value 42 accepts organization as $28+14$
37. One may have a pause here and take note that value six is the value of first perfect number while value 28 is value of the second perfect number.
38. Further as that, first perfect number value 6 accepts only 3 proper divisors (1, 2, 3) while second perfect number (28) accepts five divisors (1, 2, 4, 7, 14).
39. Further, as that, prime three is the biggest prime proper divisor of number 6, while prime 7 is the biggest prime proper divisor of number 28.
40. One may have a pause here and take note that number value 42 is the synthesis value of a pair of spatial order transcendence ranges: $[(2+3+4+5+6)+(2)+(2+3+4+5+6)] = 42$.

41. One may have a pause here and take note that value 42 accepts organization as $[(1+2+3+4+5+6)+(1+2+3+4+5+6)] = 42$, which is parallel to twice application of Sathapatya measuring rod synthesized by hyper cubes 1 to 6 parallel to swapping of 6-space domain.
42. One shall sit comfortably and to permit the transcending mind to glimpse and imbibe above format and features of pair of formulation Pind (पिण्ड) and Bramand (ब्रह्माण्ड).

(ब्रह्माण्ड)

$$(7+1+1+9+9+2+7+5+1 = 42)$$

ब्र	-	ट	ह	म्	आ	ण्	ड्	अ
7	1	1	9	9	2	7	5	1

43. One may have a pause here and take note that the word formulation (ब्रह्माण्ड) is a composition of nine letters and three syllables of three letters each of transcendental code values triple $(7+1+1, 9+9+2, 7+5+1)$.
44. One shall sit comfortably and to permit the transcending mind to glimpse and imbibe the values and features of triple transcendental code values $(9, 20, 13)$.
45. Values triple $(9, 20, 13)$ in a sequential format as $(9, 13, 20)$ is of organization feature $(9, 9+4, 9+7+4)$.
46. Value 9 is parallel to 9 versions of hyper cube 4.
47. Value 13 is parallel to the transcendence of transcendence spectrum of transcendental origin of 4-space $(4+5+4)$.
48. Value 20 is parallel to the synthesis of single, double, triple and quadruple synthetic set up of self referral dimension (6-space as dimension).

49. One may have a pause here and take note that single self referral dimension contribute value '6'.
50. Pair of self referral dimensions contribute value '8'.
51. Triple self referral dimensions contribute value '6'.
52. Quadruple self referral dimensions contribute value '0'.
53. One may have a pause here and take note that as the quadruple self referral dimension contribute only value zero, as such the contribution of single, double and triple self referral dimensions comes to be (20).
54. One may further have a pause here and take note that 5-space is a solid order space (3-space plays the role of dimension of 5-space).
55. Solid dimensional order (3-space as dimension) structure four folds manifestation layer (3, 4, 5, 6) of hyper cube 5 with 6-space in the role of origin of 5-space.
56. One shall sit comfortably and to permit the transcending mind to continuously remain in prolonged sitting of trans and to glimpse and imbibe the transcendental phenomenon of transcendental origin of creator's space transcending out from within the 9th versions of hyper cube 4, and a step ahead, there to be the transcendence of self referral origin of transcendental origin and making the Pinda format as the manifestation format of Brahand.
57. Sadhaks fulfilled with intensity of urge to imbibe these values and features of shall continuously remain in prolonged sitting of trans.



7

Devnagri Alphabet

देवनागरी वर्णमाला

Nine Vowels स्वरः

अ इ उ ऋ लृ ए ओ ऐ औ

१ २ ३ ४ ५ ६ ७ ८ ९

१ २ ३ ४ ५ ६ ७ ८ ९

5 x 5 Varga consonants वर्गाः

कवर्ग (कु)

क् ख् ग् घ् ङ्

१ २ ३ ४ ५

चवर्ग (चु)

च् छ् ज् झ् ञ्

२ ३ ४ ५ ६

टवर्ग (टु)

ट् ठ् ड् ढ् ण्

३ ४ ५ ६ ७

तवर्ग (तु) त् थ् द् ध् न्

4 5 6 7 8

पवर्ग (पु) प् फ् ब् भ् म्

5 6 7 8 9

Anthstha letters: य् र् ल् व्

अन्तस्थ 1 3 5 7

Ushmana letters: श् स् ष् ह्

उष्मणः 2 3 6 9

Yama letters यमः

• अ इ ए ऋ ॠ ऌ ॡ

9 10 11 12 13 14 15 16

■